



**SF 324 / SF 338 / SF 344 / SF 344-8**

Vorschubapparat

power feeder

- über Zweistangenstativ jede Arbeitsposition leicht einstellbar
- rechts/links Lauf
- 2 Stufenmotor, ausgenommen SF 324
- Präzisionsgetriebe gewährleistet eine exakt gleichmäßige Vorschubgeschwindigkeit und lange Lebensdauer

- every working position easily adjustable with dual rod device
- CW/CCW rotation
- 2 step motor, except SF 324
- precise gear ensures steady feeding at every speed and high durability

SF 324

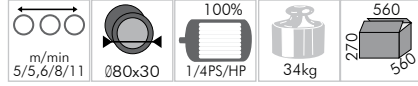

statt/instead of 643.--  
**459,--**

SF 338

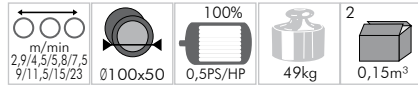

statt/instead of 923.--  
**659,--**

SF 344

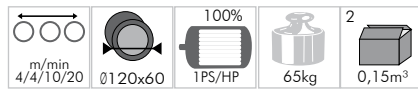

statt/instead of 1.063.--  
**759,--**

SF 344-8

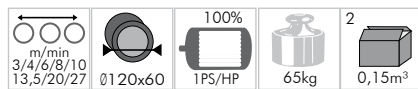

statt/instead of 1.119.--  
**799,--**



SF 324

**HOLZBEARBEITUNG**  
**WOOD WORKING**



SF 338



Multifunktionsgelenk für vertikalen u. horizontalen Betrieb  
multifunctional joint allows vertical a. horizontal operation

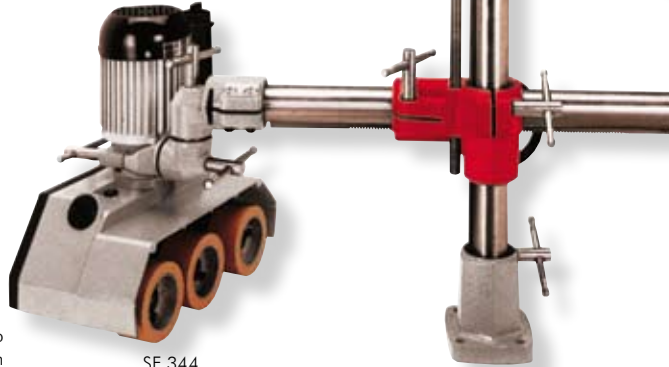

SF 344

**SF 444 / SF 444-8**

Vorschubapparat

power feeder

- durch 4 Rollensystem ideale Führung des werkstückes
- über Zweistangenstativ jede Arbeitsposition Leicht einstellbar
- rechts/links Lauf
- 2 Stufenmotor
- Präzisionsgetriebe gewährleistet eine exakt gleichmäßige Vorschubgeschwindigkeit und lange Lebensdauer

- 4-rollers ensure an ideal work piece movement
- every working position easily adjustable with dual rode device
- CW/CCW rotation
- 2 step motor
- precise gear ensures steady feeding at every speed and durability

SF 444

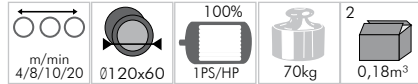

statt/instead of 1.119.--  
**799,--**

SF 444/8

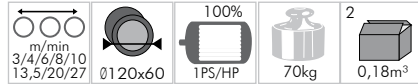

statt/instead of 1.175.--  
**839,--**

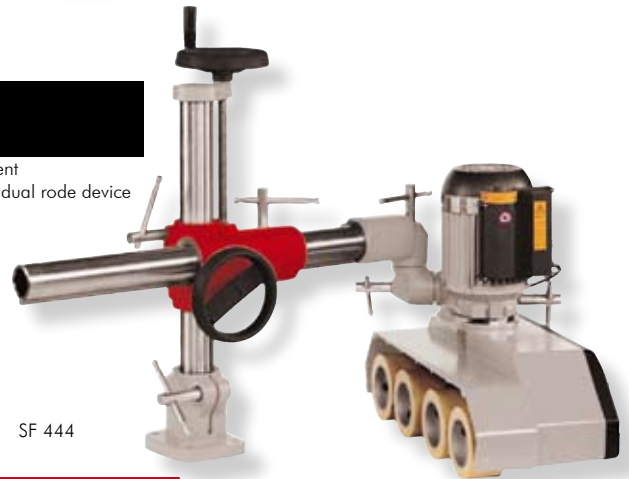

SF 444



2-Stufenmotor (2xlinks, 2xrechts)  
2-step motor (2 speeds left and right)  
(SF 344 / SF 444)